

PALLET JACK SCALE



CARBON STEEL



STAINLESS STEEL



**EASY TO USE
INDICATOR WITH
BUILT IN PRINTER**



Having a scale built into your pallet jack will increase efficiency and productivity by eliminating the need to place your pallet on a scale to weigh, saving time and money. Tufner's Pallet Jacks are rugged, precise, efficient and cost effective. They are the ideal solution for mobile weighing.

FEATURES

- Quickly verify inbound and outbound freight
- Ergonomic full function hydraulic pump handle for easy lifting, steering and weighing
- Convenient 3-stage (raise, neutral, lower) fingertip control and safety loop handle
- Reinforced construction for heavy and long term use
- Effortless steering on flat or uneven surfaces
- Super low 2.9" profile with tapered fronts forks for easy pallet entrance
- 120V rechargeable battery (operates up to 60 hours)
- Includes a built-in LCD display and optional built-in thermal printer
Units: lb and kg switchable
- Single wheel design helps prevent jack from getting stuck or breaking your pallet compared to double wheeled designs
- Small raised entry wheels inside the forks help guide when rolling into a pallet

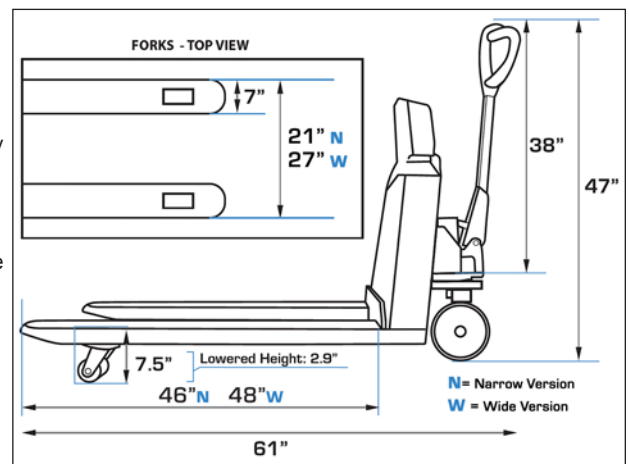

MODEL	MATERIAL	CAPACITY	FORK SIZE	PRINTER	SHIP WT.
T918-N-5	Carbon Steel	5,000 lb x 1 lb	46" L x 21" W x 2.9" H	No	350 lbs
T918-N-P-5	Carbon Steel	5,000 lb x 1 lb	46" L x 21" W x 2.9" H	Yes	360 lbs
T918-W-5	Carbon Steel	5,000 lb x 1 lb	48" L x 27" W x 2.9" H	No	350 lbs
T918-W-P-5	Carbon Steel	5,000 lb x 1 lb	48" L x 27" W x 2.9" H	Yes	360 lbs
T918-SS-3.3	Stainless Steel	3,300 lb x 1 lb	48" L x 27" W x 2.9" H	No	350 lbs
T918-SS-P-3.3	Stainless Steel	3,300 lb x 1 lb	48" L x 27" W x 2.9" H	Yes	360 lbs

NTEP CC 18-074 Class III 3,000 d - NTEP 5,000 lb x 2 lb & 3,000 lb x 1 lb